

# SYS 1319-T2

# Desktop

# 10~30W

Country of Origin : China  
 Operating Temperature : 0 ~ 40° C  
 Dimension : 86.5 x 47 x 33 mm  
 Approvals / Marks : c-UL, TÜV, CE, CB



### Features:

Universal range 90~264VAC / 47~63Hz  
 Overload, Over Voltage & Short Circuit protection  
 1 year warranty  
 Available with IEC320-C8 (T2) or IEC320-C6 (T3) inlet

### Specification:

		OUTPUT						
	MODEL	Voltage	min. Load	max. Load	Tolerance	Ripple & N.	Efficiency	Max. Power
OUTPUT	SYS1319-1005	5V	0A	2A	±5%	50mV	80% min.	10W
	SYS1319-2005	5V	0A	4A	±5%	50mV	80% min.	20W
	SYS1319-2106	6V	0A	3.50A	±5%	60mV	80% min.	21W
	SYS1319-2709	9V	0A	3A	±5%	100mV	80% min.	27W
	SYS1319-3012	12V	0A	2.5A	±5%	120mV	80% min.	30W
	SYS1319-3015	15V	0A	2A	±5%	150mV	80% min.	30W
	SYS1319-3016	16V	0A	1.87A	±5%	160mV	80% min.	30W
	SYS1319-3018	18V	0A	1.66A	±5%	180mV	80% min.	30W
	SYS1319-3019	19V	0A	1.57A	±5%	200mV	80% min.	30W
	SYS1319-3020	20V	0A	1.5A	±5%	200mV	80% min.	30W
	SYS1319-3024	24V	0A	1.25A	±5%	240mV	80% min.	30W
INPUT	Voltage	90 ~ 264VAC						
	Frequency	47 ~ 63Hz						
	Current (rms max)	1A at AC low line input and DC output full load						
	Leakage Current	< 0.25mA						
	Surge Current	< 60A @ 230VAC / < 40A @ 115VAC						
PROTECTION	Overload	> 120% Fold back						
	Over Voltage	> 105% Voltage limiting						
	Short Circuit	Yes , Output to Ground, Auto recovery when fault has been removed						
	Input	1.6A fuse against power line surges and any abnormal conditions						
	No Load Operation	Yes , to protect the power supply and system from damage						
OTHERS	Setup time	3s max. @ AC low line Input and Output full load						
	Holdup time	10ms @ AC nominal Input and Output full load						
	Cooling	Free air convection						
	Withstand Voltage	HI-POT B : I/P-O/P (FG): 3KVAC / 10mA / 1 minute						
	Power Consumption	Max. 75W @ AC nominal Input and Output min. load						
Environment	Temperature	Operating: 0 ~ 40°C / Storage: -20 ~ 85°C						
	Humidity	Operating: 8% ~ 90% RH / Storage: 5% ~ 95% RH						
Connection	Output	Plug: standart 5.5 x 2.1 x 11mm (spring loaded center) or customer requirement / Cable: 180cm ( 6ft. )						
	Input	IEC320-C8						
MTBF	> 35K hours							
SAFETY	TÜV EN60950-1 :2001 / CE / CB							
EMC	EMI	EN55022 Class B (1998)+A1(2000)+A2(2003), EN 61000-3-2(2000), EN 61000-3-3(1995)+A1(2001)						
	EMS	EN55024 (1998) +A1(2000) +A2(2003): IEC 61000-4-2(2001) IEC 61000-4-3(2002), IEC 61000-4-4(2004), IEC 61000-4-5(2001), IEC 61000-4-6(2003)+A1(2004), IEC 61000-4-8(2001), IEC 61000-4-11(2004)						
WEIGHT	N.W.: 0.20 kg							

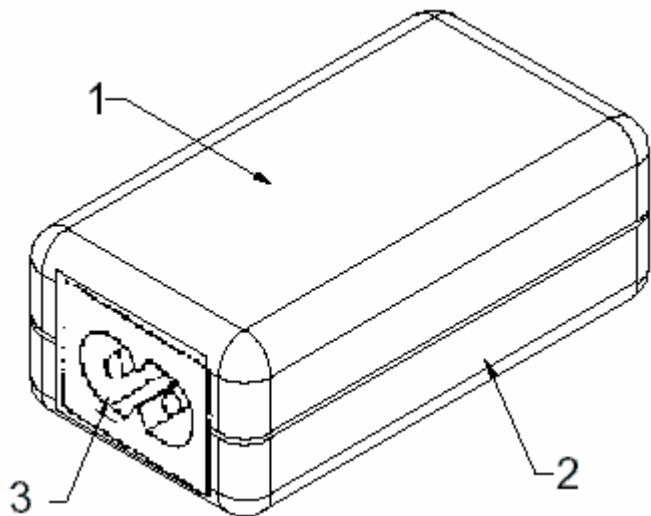
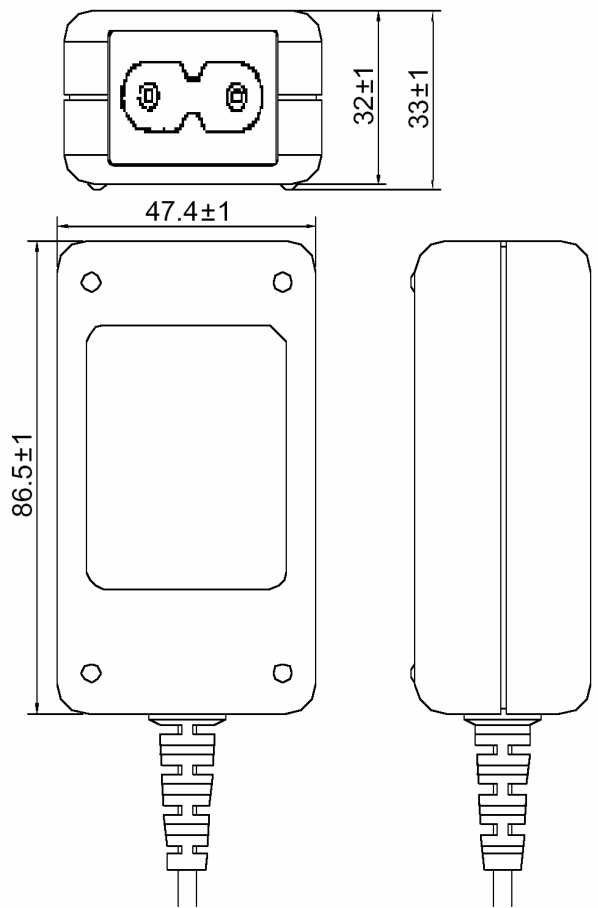

3	socket			
2	BOTTOM	(G)1061152B044*	BLACK	PPO
1	TOP	(G)1061117B043*	BLACK	PPO
NO.	NAME	PART NO	COLOR	MATERIAL

MODEL NAME	SYS1319-T3			APPROVAL 2	ISSUED STAMP				
PART NO.		UNIT	mm	APPROVAL 1					
DRAWING NAME	APPEARANCE	TOLERANCES UNLESS OTHERWISE SPECIFIED		ENGINEER					
PART NAME		0.5-6	±0.1	DRAWING BY	huang de sheng 6/8				
		6-30	±0.2						
DWG PATH:		30-120	±0.3	DOC.NO.		SCALE	5:9	SHEET	1of1
		120-315	±0.4						